

WATERPROOF STRAIGHT JACK CRIMP+HOUSING

R197.134.D11

CABLE 2.6/50S

Series : **SMB**
CARLOCK

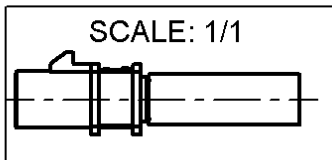
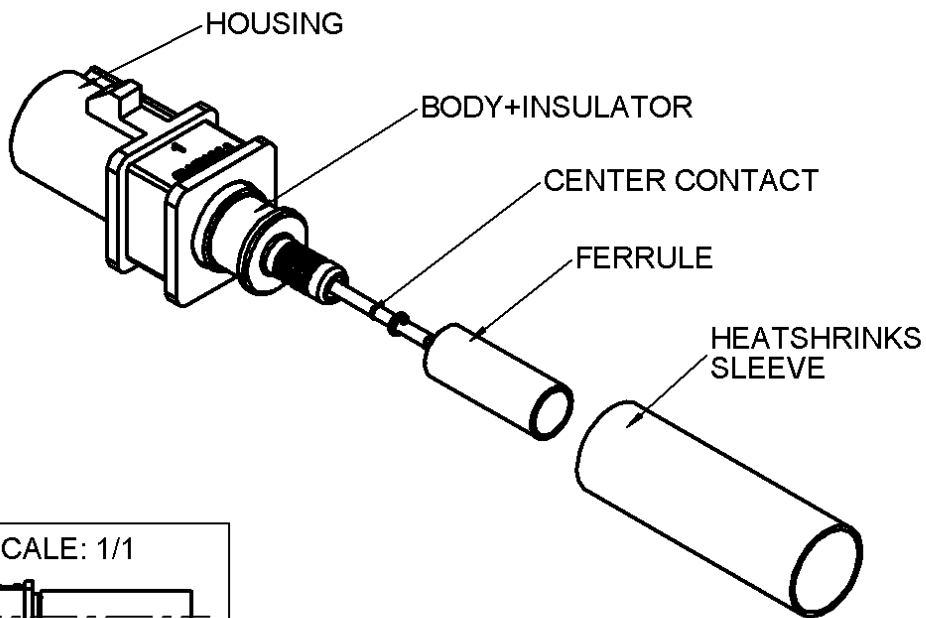
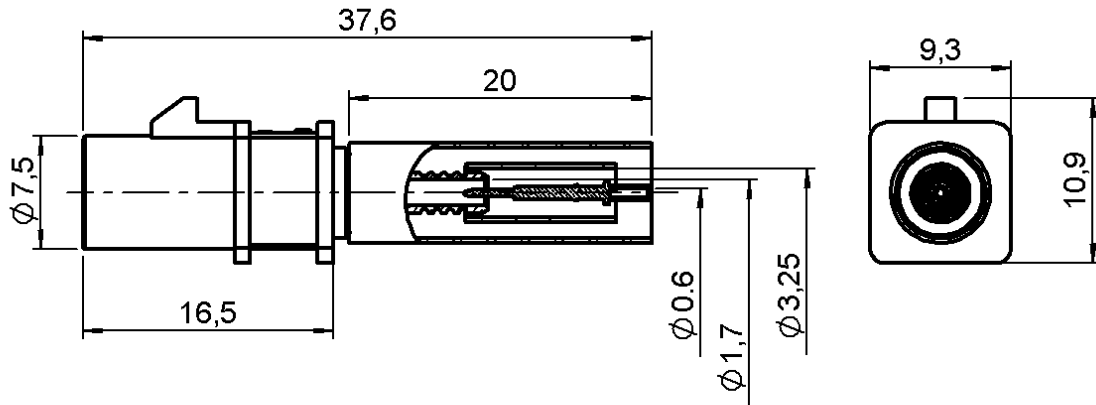

IP67 with the connector R197.114.D11 only

All dimensions are in mm.



COMPONENTS	MATERIALS	PLATING (µm)
BODY	BRASS	NICKEL 2
CENTER CONTACT	BRASS	GOLD 0.8 OVER NICKEL 2
OUTER CONTACT	-	-
INSULATOR	PTFE	
GASKET	NBR 70	
OTHERS PARTS	BRASS	NICKEL 2
HOUSING	PA6.6 GF15 (POLYAMIDE)	UL CLASSIFICATION COLOR
		UL 94 V-2 SEE PAGE 3

Issue : 0647 A

In the effort to improve our products, we reserve the right to make changes judged to be necessary.



WATERPROOF STRAIGHT JACK CRIMP+HOUSING

R197.134.D11

CABLE 2.6/50S

Series : **SMB**
CARLOCK

PACKAGING

Standard	Unit	Other
100	'W' option	Contact us

SPECIFICATION

QS9000

ELECTRICAL CHARACTERISTICS

Impedance	50	Ω
Frequency	0-4	GHz
VSWR	TBD + 0,0000	x F(GHz) Maxi
Insertion loss	TBD	\sqrt{F} (GHz) dB Maxi
RF leakage	- (TBD	- F(GHz)) dB Maxi
Voltage rating	335	Veff Maxi
Dielectric withstanding voltage	1000	Veff mini
Insulation resistance	1000	M Ω mini

CABLE ASSEMBLY

Stripping	a	b	c	d	e	f
mm	2,50	5,50	13,6	0,00	11,1	0,00

Assembly instruction : **See page 4**

Recommended cable(s)

RG 174

RG 316

Characteristics indicated on this data sheet are those that can be achieved with the highest performance cable. Intrinsic limitations of the cable may diminish the performance of the assembly

Cable retention

- pull off	RG174	65* N mini
	RG316	110 N mini
- torque	NA N.cm	

MECHANICAL CHARACTERISTICS

Center contact retention		
Axial force – Mating end	10	N mini
Axial force – Opposite end	10	N mini
Torque	NA	N.cm mini

TOOLING

Part Number	Description	Hexagon
.	.	.
R282.235.915	CRIMPING DIES	Hex 3.25 Square 0.72
R282.271.000	CRIMPING TOOL	Hex 3.25 Square 0.72
R282.281.000	CRIMPING TOOL	2x4 pts 3pos
R282.293.000	CRIMPING TOOL	
R282.967.034	POSITIONER FOR TOOL R282 281	

Recommended torque		
Mating	NA	N.cm
Panel nut	NA	N.cm
Clamp nut	NA	N.cm
A/F clamp nut	0,0000	mm
Mating life	10	Cycles mini
Weight	3,0000	g

ENVIRONMENTAL

Operating temperature	-40/+110	$^{\circ}$ C
Hermetic seal	NA	Atm.cm3/s
Panel leakage	IP67	

OTHER CHARACTERISTICS

*Depends on the cable used

Issue : **0647 A**

In the effort to improve our products, we reserve the right to make changes judged to be necessary.



WATERPROOF STRAIGHT JACK CRIMP+HOUSING

R197.134.D11

CABLE 2.6/50S

Series : SMB
CARLOCK

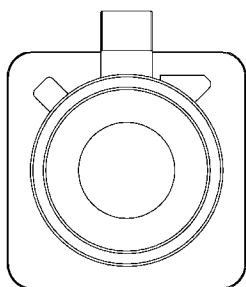

CODING A
 COLOR BLACK
 RAL 9005

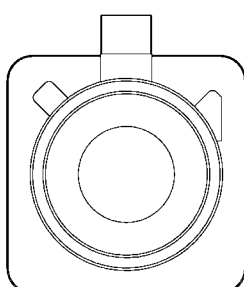

CODING B
 COLOR WHITE
 RAL 9003

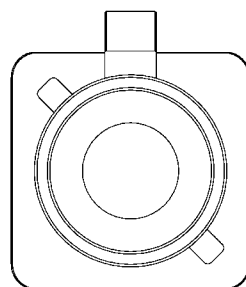

CODING C
 COLOR BLUE
 RAL 5005

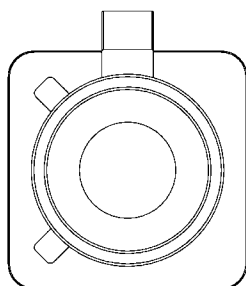

CODING D
 COLOR BORDEAUX
 VIOLET
 RAL 4004

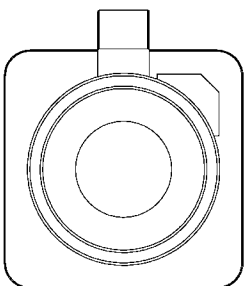

CODING E
 COLOR GREEN
 RAL 6002

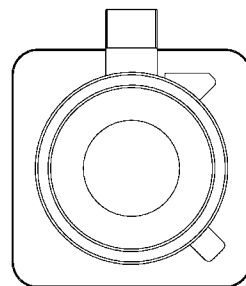

CODING F
 COLOR BROWN
 RAL 8011

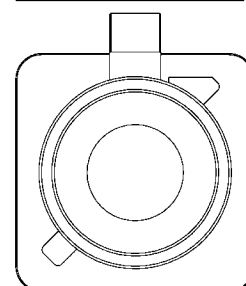

CODING G
 COLOR GREY
 RAL7031

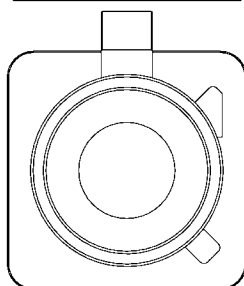

CODING H
 COLOR VIOLET
 RAL 4003

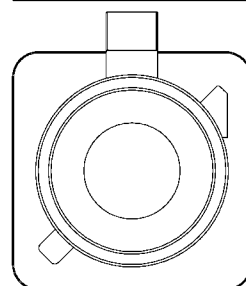

CODING I
 COLOR BEIGE
 RAL 1001

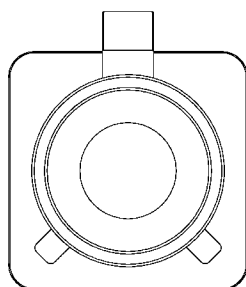

CODING K
 COLOR CURRY
 RAL 1027

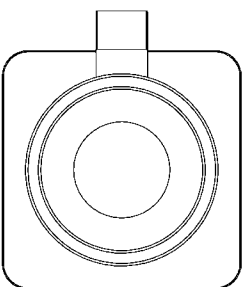

CODING Z
 COLOR WATER BLUE
 RAL 5021

UL CLASSIFICATION
 UL 94V-2

*According to FAKRA specifications

-To obtain the complete P/N please fill in the blank " _ " with the coding letter

Issue : 0647 A

In the effort to improve our products, we reserve the right to make changes judged to be necessary.



WATERPROOF STRAIGHT JACK CRIMP+HOUSING

R197.134.D11

Series : SMB
CARLOCK

CABLE 2.6/50S

COMPONENTS

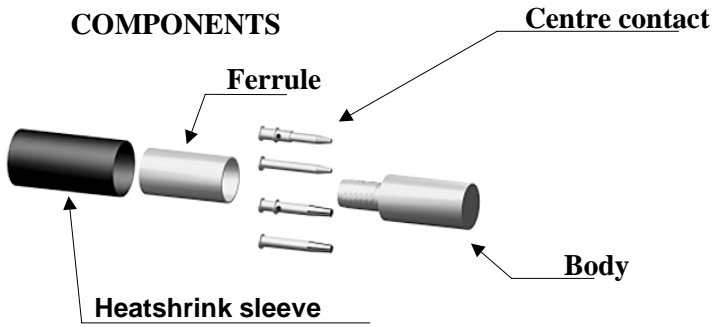

STRIPPING DIMENSIONS

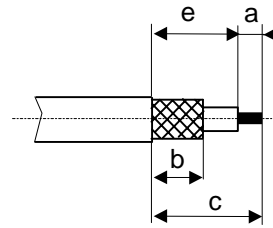

1

Slide the heatshrink sleeve onto the cable.
Slide the ferrule onto the cable.
Strip the cable.

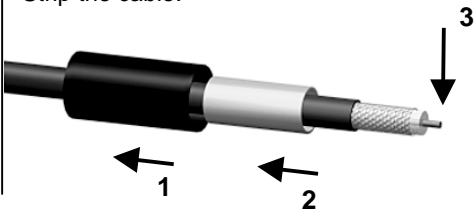

4

Slide the cable into the body until it bottoms against the insulator.

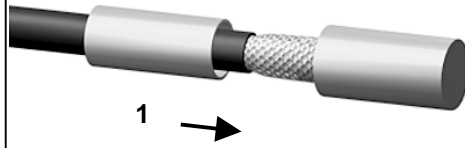

2

Slide the centre contact on until it bottoms against the cable dielectric.
Crimp the centre contact.
Clean solder area.



5

Slide the ferrule over the braid.
Crimp the ferrule with crimping tool (see connector TDS).

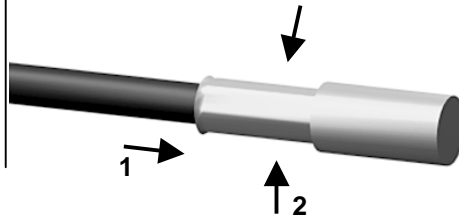

3

Fan the braid.

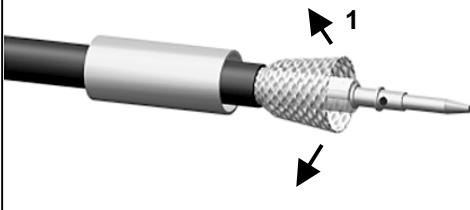

6

Cut the excess of braid if necessary.
Slide the sleeve over the ferrule and heatshrink it in place.

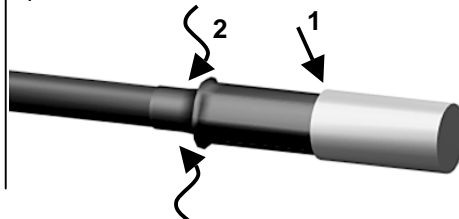

Issue : 0647 A

In the effort to improve our products, we reserve the right to make changes judged to be necessary.

